



Specification

DESIGN

Center body consists of 1 part to be mounted between two flanges according to EN 1092-1 type 11 form B - PN10 (former DIN 2501). ANSI 150 on request.

MEDIA

Liquid and pulverised media with fibre particles, viscous media, drain water, sludge, food etc. (plastic granulates, sand or similar media on request). Not suitable for steam.

BODY

- GG-25 (grey cast iron), polyester-coated (heattreatment 190°C, 20min)
- stainless steel 1.4408.

SEALING

- Metal/metal
 - NBR
 - EPDM
- (FKM or PTFE on request)

GLAND

- 3-piece sealing set:
- 2x natural/synthetisch fibre, PTFE-coated
 - 1x NBR-, EPDM or FKM-ring

KNIFE

Stainless steel 1.4301 or 1.4401 (304 or 316)

STEM

Stainless steel 1.4305 or 1.4404 (304 or 316)

HAND WHEEL

Steel, lacquered

PRESSURE DISCHARGE

One-sided, two-sided on request

STEM

Not rising

PRESSURE RANGE

Please refer to the table

TEMPERATURE RANGE

- metal: on request
- NBR: -25°C ... +90°C
- EPDM: -35°C ... +120°C

Attention: Temperature range not for all media.

FACE TO FACE

EN 558-1 Row 20

The above information is intended for guidance only and the company reserves the right to change any data herein without prior notice!

Technische Daten

AUSFÜHRUNG

1-teiliges Zentriergehäuse zum Einklemmen zwischen Flansche nach EN 1092-1 Typ 11 Form B - PN10 (früher DIN 2501). ANSI 150 auf Anfrage.

DURCHFLUSSMEDIUM

Flüssigkeiten und pulverförmige Medien mit Faseranteilen, zähflüssige Medien, Abwasser, Klärschlamm, Lebensmittel usw. (Kunststoffgranulate, Sand oder ähnliche Materialien auf Anfrage). Nicht geeignet für Dampf.

GEHÄUSE

- GG-25, Polyester-beschichtet (eingebraunt 190°C, 20min)
- Edelstahl 1.4408

DICHTUNG

- metallisch
 - NBR
 - EPDM
- (FKM oder PTFE auf Anfrage)

STOPFBUCHSPACKUNG

- 3-teiliger Dichtungssatz:
- 2x Naturfaser/synthetisch, PTFE-beschichtet
 - 1x NBR-, EPDM oder FKM-Ring

SCHIEBERBLATT

Edelstahl 1.4301 bzw. 1.4401

SPINDEL

Edelstahl 1.4305 oder 1.4404

HANDRAD

Stahl, lackiert

DRUCKBEAUFSCHLAGUNG

einseitig, beidseitig auf Anfrage

SPINDEL

nicht steigend

BETRIEBSDRUCK

siehe Tabelle

MEDIUMTEMPERATUR

- metallisch: auf Anfrage
- NBR: -25°C ... +90°C
- EPDM: -35°C ... +120°C

Beachten: Die Temperaturen gelten nicht für alle Medien.

BAULÄNGE

EN 558-1 Reihe 20

Alle Angaben sind freibleibend und unverbindlich!

Type:

WGE-xx-MW

Knife-Gate-Valve
handwheel

DN50 ... DN400

GG-25, Stainless steel

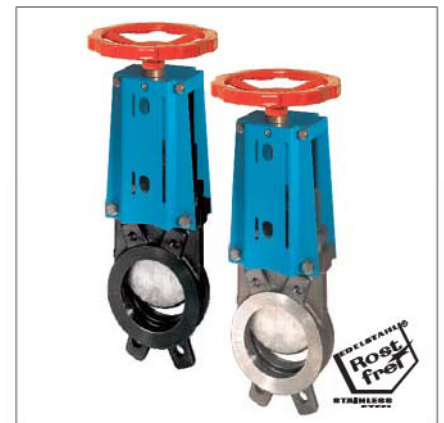

Artikel:

WGE-xx-MW

Stoffschieber
Handrad

DN50 ... DN400

GG-25, Edelstahl

Features [Vorteile]

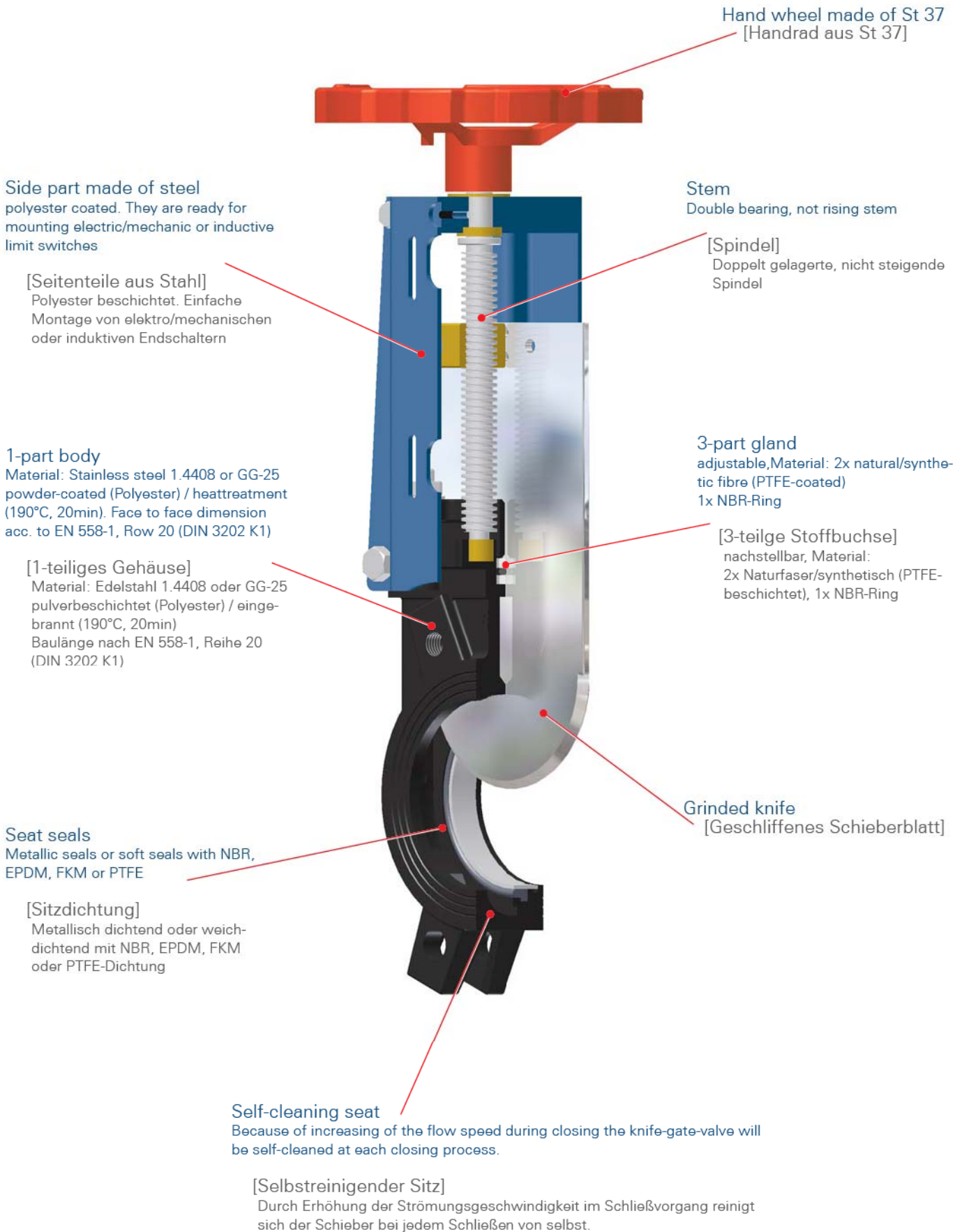

Article number key
[Artikelnummernschlüssel]

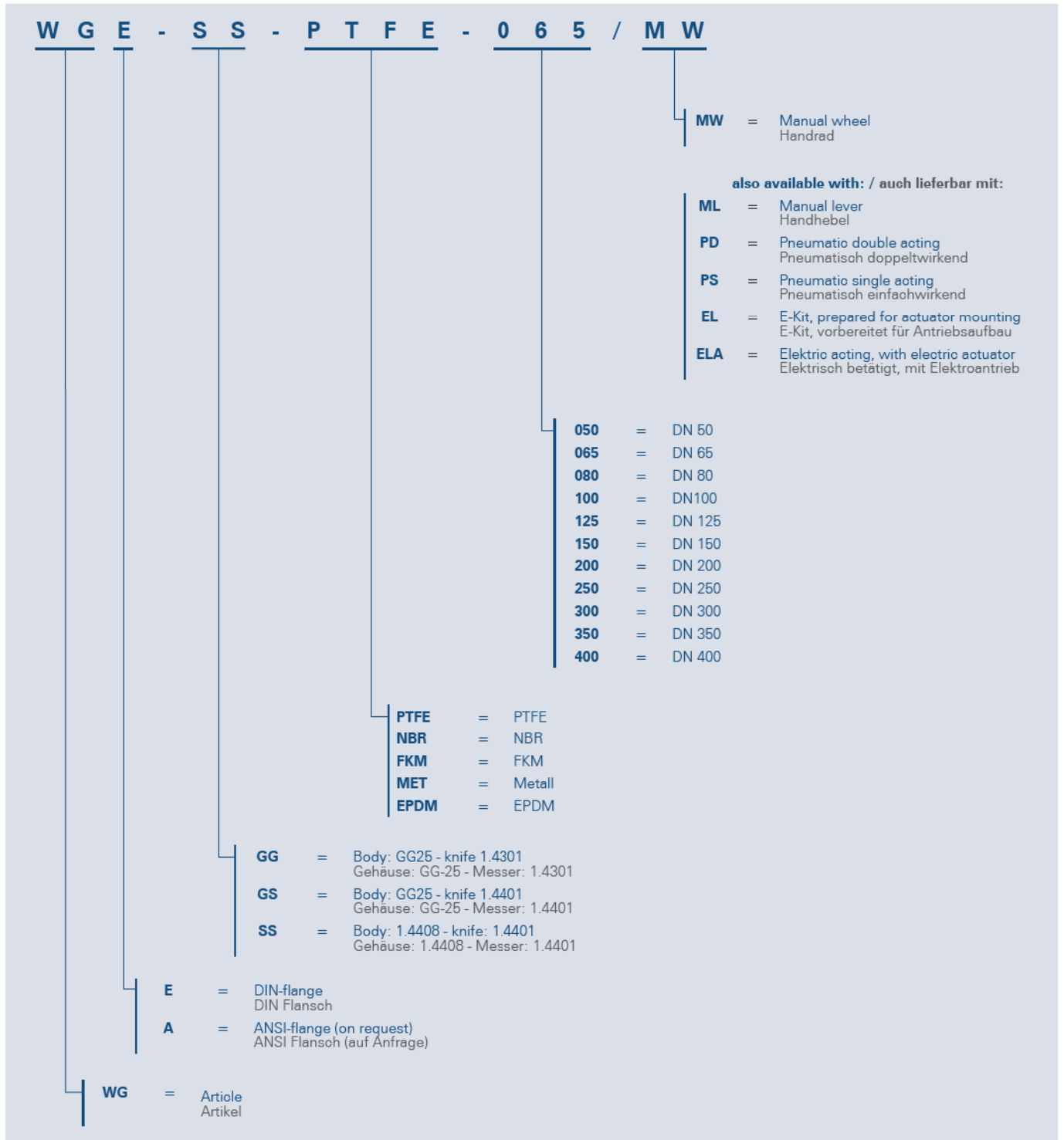

Leaking rate
[Leckrate]

Please note that you have to calculate for all metallic sealing knife-gate-valves with a leaking rate of appr. 0,4% of the Kv-value (for liquid media).

Bitte beachten Sie, das bei metallisch dichtenden Stoffschiebern mit einer Leckrate von 0,4% vom Kv-Wert zu rechnen ist (dünnflüssige Medien).

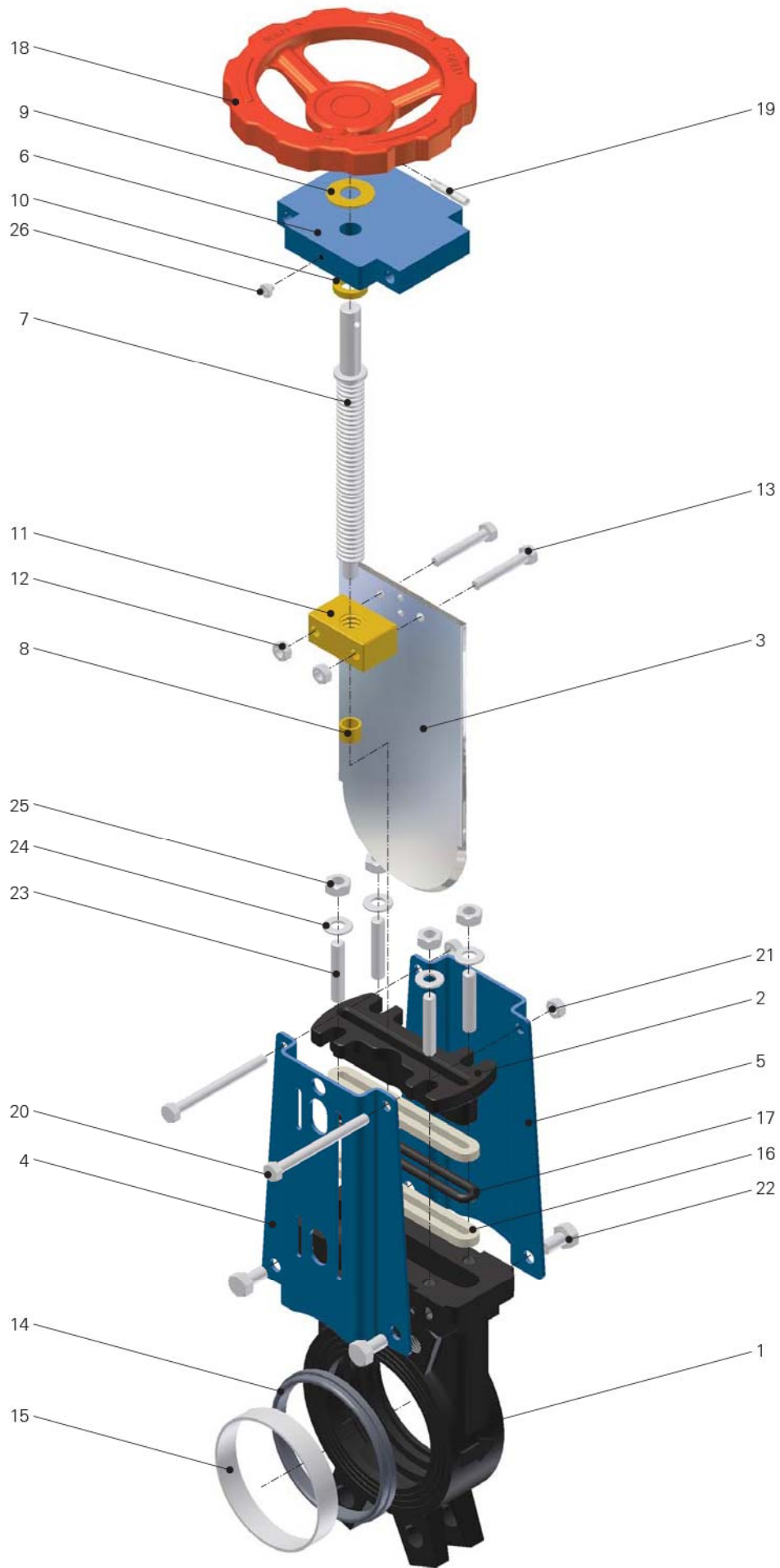

Parts list | grey cast iron
[Stückliste | GG-25]

Pos.	Description	Material	[Bezeichnung]	[Material]
1	Body	Grey cast iron	Gehäuse	Grauguß GG-25
2	Gland	Grey cast iron	Stopfbuchsbrille	Grauguß GG-25
3	Knife	Stainless steel 1.4301	Schieberblatt	Edelstahl 1.4301
4	Side part	Steel, polyester coated	Seitenteil	Stahl, Polyester beschichtet
5	Side part	Steel, polyester coated	Seitenteil	Stahl, Polyester beschichtet
6	Top plate	Steel, polyester coated	Lagerplatte	Stahl, Polyester beschichtet
7	Stem	Stainless steel 1.4305	Spindel	Edelstahl 1.4305
8	Bushing	Brass	Buchse	Messing
9	Disc	Brass	Scheibe	Messing
10	Disc	Brass	Scheibe	Messing
11	Stem nut	Bronze	Spindelmutter	Bronze
12	Hexagon nut	Steel, galvanised	Sechskantmutter	Stahl, verzinkt
13	Screw	Steel, galvanised	Schraube	Stahl, verzinkt
14	Sealing	NBR / EPDM / FKM / PTFE	Dichtung	NBR / EPDM / FKM / PTFE
15	Seat ring	Stainless steel	Sitzring	Edelstahl
16	Gland	Natural fibre, PTFE-coated	Stopfbuchspackung	Naturfaser, PTFE-beschichtet
17	Gland	NBR-ring	Stopfbuchspackung	NBR-Ring
18	Hand wheel	Steel, lacquered	Handrad	Stahl, lackiert
19	Pin	Stainless steel	Stift	Edelstahl
20	Screw	Steel, galvanised	Schraube	Stahl, verzinkt
21	Hexagon nut	Steel, galvanised	Sechskantmutter	Stahl, verzinkt
22	Screw	Steel, galvanised	Schraube	Stahl, verzinkt
23	Threaded pin	Steel, galvanised	Gewindestift	Stahl, verzinkt
24	Disc	Steel, galvanised	Scheibe	Stahl, verzinkt
25	Hexagon nut	Steel, galvanised	Sechskantmutter	Stahl, verzinkt
26	Lubrication nipple	Steel, galvanised	Schmiernippel	Stahl, verzinkt

Parts list | stainless steel
[Stückliste | Edelstahl]

Pos.	Description	Material	[Bezeichnung]	[Material]
1	Body	Stainless steel 1.4408	Gehäuse	Edelstahl 1.4408
2	Gland	Stainless steel 1.4408	Stopfbuchsbrille	Edelstahl 1.4408
3	Knife	Stainless steel 1.4401	Schieberblatt	Edelstahl 1.4401
4	Side part	Steel, polyester coated	Seitenteil	Stahl, Polyester beschichtet
5	Side part	Steel, polyester coated	Seitenteil	Stahl, Polyester beschichtet
6	Top plate	Steel, polyester coated	Lagerplatte	Stahl, Polyester beschichtet
7	Stem	Stainless steel 1.4404	Spindel	Edelstahl 1.4404
8	Bushing	Brass	Buchse	Messing
9	Disc	Brass	Scheibe	Messing
10	Disc	Brass	Scheibe	Messing
11	Stem nut	Bronze	Spindelmutter	Bronze
12	Hexagon nut	Stainless steel	Sechskantmutter	Edelstahl
13	Screw	Stainless steel	Schraube	Edelstahl
14	Sealing	NBR / EPDM / FKM / PTFE	Dichtung	NBR / EPDM / FKM / PTFE
15	Seat ring	Stainless steel	Sitzring	Edelstahl
16	Gland	Natural fibre, PTFE-coated	Stopfbuchspackung	Naturfaser, PTFE-beschichtet
17	Gland	NBR-ring	Stopfbuchspackung	NBR-Ring
18	Hand wheel	Steel, lacquered	Handrad	Stahl, lackiert
19	Pin	Stainless steel	Stift	Edelstahl
20	Screw	Steel, galvanised (stainless steel on req.)	Schraube	Stahl, verzinkt (Edelstahl auf Anfrage)
21	Hexagon nut	Steel, galvanised (stainless steel on req.)	Sechskantmutter	Stahl, verzinkt (Edelstahl auf Anfrage)
22	Screw	Steel, galvanised (stainless steel on req.)	Schraube	Stahl, verzinkt (Edelstahl auf Anfrage)
23	Threaded pin	Stainless steel	Gewindestift	Edelstahl
24	Disc	Stainless steel	Scheibe	Edelstahl
25	Hexagon nut	Stainless steel	Sechskantmutter	Edelstahl
26	Lubrication nipple	Steel, galvanised	Schmiernippel	Stahl, verzinkt

Dimensions
[Abmessungen]

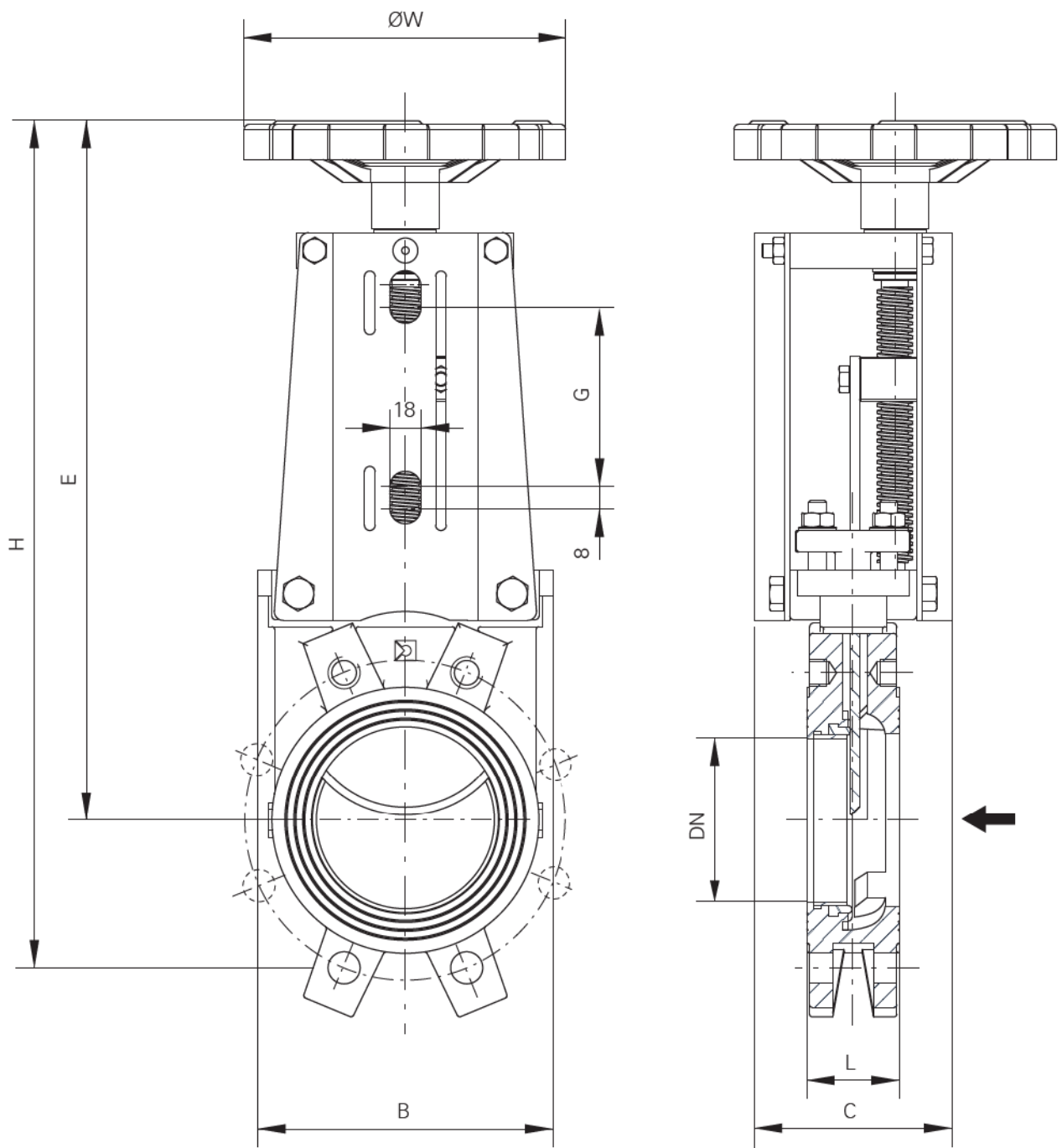

DN	inch	H	L	E	B	C	G	W	bar	kg
50	2"	372	43	328	116	102	53	200	10	8
65	2½"	405	46	354	131	102	53	200	10	9
80	3"	441	46	367	146	102	82	200	10	10
100	4"	479	52	396	166	112	102	200	10	13
125	5"	510	56	413	197	112	130	250	10	17
150	6"	573	56	462	222	112	156	250	10	20
200	8"	714	60	578	275	130	205	350	8	34
250	10"	878	68	709	332	130	270	350	7	50
300	12"	1.010	78	815	386	130	320	350	6	66
350	14"	1.180	96	955	437	196	-	400	6	105
400	16"	1.311	100	1.059	491	196	-	400	5	135

Flange and boring detail | DIN PN10 [Flansch- und Bohrungsdetail | DIN PN10]

DN	ØK	n	M	T	●	⊕
50	125	4	M16	8	2	2
65	145	4	M16	9	2	2
80	160	8	M16	9	2	2
100	180	8	M16	9	2	2
125	210	8	M16	9	2	2
150	240	8	M20	10	2	2
200	295	8	M20	10	2	2
250	350	12	M20	12	4	2
300	400	12	M20	14	4	2
350	460	16	M20	20	6	6
400	515	16	M24	23,5	6	6

● Threaded blind hole
[Sackbohrung, Gewinde]

⊕ Through hole
[Durchgangsbohrung]

DN50 - DN65

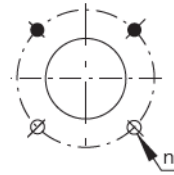

DN80 - DN200

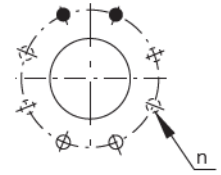

DN250 - DN300

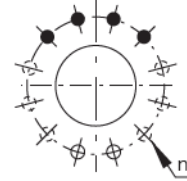

DN350 - DN400

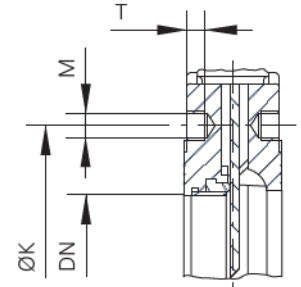
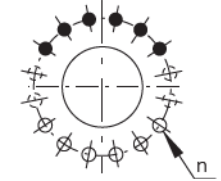

Flange and boring detail | ANSI B16.5, class 150 [Flansch- und Bohrungsdetail | ANSI B16.5, class 150]

only on request, nur auf Anfrage

DN	ØK	n	M	T	●	⊕
2"	4¾"	4	5/8" UNC	8	2	2
2½"	5½"	4	5/8" UNC	9	2	2
3"	6"	4*	5/8" UNC	9	2	2
4"	7½"	8	5/8" UNC	9	2	2
5"	8½"	8	¾" UNC	9	2	2
6"	9½"	8	¾" UNC	10	2	2
8"	11¾"	8	¾" UNC	10	2	2
10"	14¼"	12	7/8" UNC	12	4	2
12"	17"	12	7/8" UNC	14	4	2
14"	18¾"	12	1" UNC	20	4	2
16"	21¼"	16	1" UNC	23,5	6	6

* Knife-gate valves 3" will be delivered in 8-hole flange execution and valves 14" in 16 hole flange execution!

* [Stoffschieber 3" werden in 8-Loch Flanschausführung, Stoffschieber in 14" in 16-Loch Flanschausführung geliefert!]

● Threaded blind hole
[Sackbohrung, Gewinde]

⊕ Through hole
[Durchgangsbohrung]

DN2" - DN3"

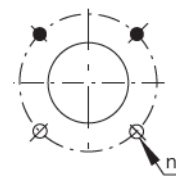

DN4" - DN8"

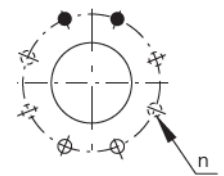

DN10" - DN14"

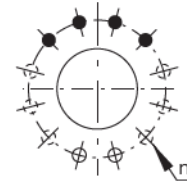

DN16"

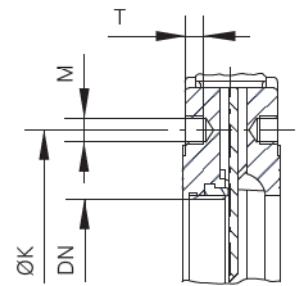
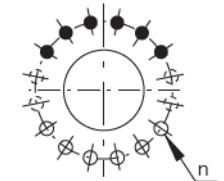

Flow rate m³/h for standrad bore - head loss

[Durchflusswerte m³/h bei Standardbohrung - Druckverlust]

DN	Head loss (bar) [Druckverlust (bar)]				
	0,2	0,4	0,6	0,8	1
50	94	144	166	185	205
65	130	180	215	270	310
80	190	310	372	424	495
100	440	620	720	824	926
125	701	925	1.135	1.335	1.545
150	920	1.342	1.545	1.902	2.055
200	1.595	2.366	2.990	3.402	4.020
250	2.470	3.505	4.431	5.150	5.660
300	4.125	5.666	6.802	7.832	8.749
350	5.333	7.369	8.735	9.705	11.645
400	6.702	9.315	11.650	13.600	15.515

EU-Declaration by the manufacturer [EU-Herstellererklärung]

as defined by Machinery Directive 98/37/EC (former 89/392/EWG, Annex II B),
we herewith declare that the knife-gate valves have been developed and designed by applying
the following harmonised standards:

EN 292	Safety of machinery
EN 983	Safety requirements for fluid power systems and components - Pneumatics
EN 60204-1	Electrical equipment of machinery

Advice

These knife-gate valves are intended to be incorporated into machinery compounds. Putting
into operation of the machinery is not allowed until such time as the entire machinery is proving
to comply completely with the EU Directive.

im Sinne der EU-Maschinenrichtlinie 98/37/EG (former 89/392/EWG, Anhang II B)
Hiermit erklären wir, dass die Stoffschieber unter Anwendung nachfolgender harmonisierter
Normen entwickelt und konstruiert wurden:

EN 292	Sicherheit von Maschinen
EN 983	Fluidtechnische Anlagen - Pneumatik
EN 60204-1	Elektrische Ausrüstung von Maschinen

Hinweis

Die Stoffschieber sind zum Einbau in eine Maschine bestimmt. Deren Inbetriebnahme
ist solange untersagt, bis festgestellt wurde, dass die Gesamtmaschine der EU-Richtlinie
entspricht.