



Qualität von Anfang an.

Technische Daten

BAUFORM

1-teilige Körperkonstruktion zum Einklemmen zwischen zwei Flansche nach **EN 1092-1 Typ 11 Form B (PN10/PN16)**.

Mit Zulassung für Gase nach DIN-DVGW / G. (nur bis DN300)

AB DN50 Baulänge nach EN 558-1 Reihe 20.

BETÄTIGUNG

90°-Drehung des Handhebels, mit Einrastmöglichkeiten. Ab DN 250 mit Getriebe.

ANSCHLUß (Standardklappe)

Flansch DN40 ... DN300
PN 6, PN 10, PN 16, ANSI 150
Flansch DN350 ... DN600
PN 6, PN 10

ANSCHLUß (LUG Type)

Flansche PN10 - PN16:
DN40 ... DN150
Flansche PN10:
DN200 ... DN600

BETRIEBSDRUCK

zwischen 2 Flanschen:

- max. 16 bar (DN40 - DN150)
- max. 10 bar (DN200 - DN600)

MEDIUMTEMPERATUR

NBR = -20°C ... + 90°C
EPDM = -20°C ... +110°C
FKM = -10°C ... +160°C

WERKSTOFFE

Gehäuse: GGG-40
Scheibe: Edelstahl 1.4408
Wellendichtung: • FKM
• EPDM
Welle: Edelstahl 1.4016
Manschette: • NBR
• FKM
• EPDM
Handhebel: Stahl

ZUSATZAUSSTATTUNG

Pneumatischer oder elektrischer Schwenkantrieb, Stellungsanzeige mit elektrisch/mechanischen oder induktiven Endschaltern.

Alle Angaben sind freibleibend und unverbindlich!

Specification

DESIGN

Body consists of 1 part, to be mounted between two flanges acc. to **EN 1092-1 Typ 11 Form B (PN10/PN16)**.

With permission for gases according to DIN-DVGW / G. (only up to DN300)

From DN50 face to face dimension acc. to EN 558-1 R20.

OPERATION

Rotation of the handle through 90°, with snap-in positions. From DN 250 with gear box.

CONNECTION (Standard version)

Flange DN40 ... DN300
PN 6, PN 10, PN 16, ANSI 150
Flange DN350 ... DN600
PN 6, PN 10

ANSCHLUß (LUG Type)

Flange PN10 - PN16:
DN40 ... DN150
Flange PN10:
DN200 ... DN600

PRESSURE RANGE

between 2 flanges:

- max. 16 bar (DN40 - DN150)
- max. 10 bar (DN200 - DN600)

TEMPERATURE RANGE

NBR = -20°C ... + 90°C
EPDM = -20°C ... +110°C
FKM = -10°C ... +160°C

MATERIALS

Body: GGG-40
Disc: Stainless steel 1.4408
Shaft seal: • FKM
• EPDM
Shaft: Stainless Steel 1.4016
Seat: • NBR
• FKM
• EPDM
Handle: carbon steel

OPTIONS

Pneumatic or electric actuator, electric position indicator with electric/mechanical or inductive proximity switches.

The above information is intended for guidance only and the company reserves the right to change any data herein without prior notice!

Artikel:

BA / BM

Absperrklappe
mit DVGW-Zulassung

GGG-40



Type:

BA / BM

Butterfly valve
with DVGW approval

GGG-40

Artikel- u. Bestellangaben: z.B. BA534610

= Absperrklappe nach DVGW, GGG-40 Edelstahl, EPDM, DN 100

1.+ 2. Stelle Produkt	3. Stelle Gehäusewerkstoff	4. Stelle Scheibenwerkstoff	5. Stelle Manschettenwerkstoff	6. Stelle Zusatzausstattung	7.+ 8. Stelle Anschlußgröße
BA = Absperrklappe, Einklemmgehäuse	5 = GGG-40	3 = Edelstahl 1.4408	2 = NBR 3 = FKM 4 = EPDM	6 = DIN - DVGW/G Zulassung (nur bis DN300)	06 = DN 40 07 = DN 50 08 = DN 65 09 = DN 80 10 = DN 100 11 = DN 125 12 = DN 150 13 = DN 200 14 = DN 250 15 = DN 300 16 = DN 350 17 = DN 400 19 = DN 500 20 = DN 600
BM = Absperrklappe, LUG- TYPE					

Ordering example: e.g. BA534610

= Butterfly valve acc. to DVGW, GGG-40, Stainless steel, EPDM, DN 100

1.+ 2. Digit Product	3. Digit Body material	4. Digit Disc material	5. Digit Seat material	6. Digit Options	7.+ 8. Digit Connection size
BA = Butterfly valve, WAFER- Type	5 = GGG-40	3 = Stainless steel 1.4408	2 = NBR 3 = FKM 4 = EPDM	6 = DIN - DVGW/G permission (only up to DN300)	06 = DN 40 07 = DN 50 08 = DN 65 09 = DN 80 10 = DN 100 11 = DN 125 12 = DN 150 13 = DN 200 14 = DN 250 15 = DN 300 16 = DN 350 17 = DN 400 19 = DN 500 20 = DN 600
BM = Butterfly valve, LUG- TYPE					

Hinweis

Bei den in dieser Dokumentation beschriebenen Produkten, in der von uns gelieferten Form, handelt es sich weder um Maschinen gemäß Artikel 2 Absatz a noch um unvollständige Maschinen gemäß Artikel 2 Absatz g im Sinne der Richtlinie 2006/42/EG über Maschinen.

Advice

The products described in this documentation in the conditions of our delivery are no machinery according to annex 2 paragraph a respectively no partly completed machinery according to annex 2 paragraph g of the directive 2006/42/EC on machinery.

Stückliste / Parts list

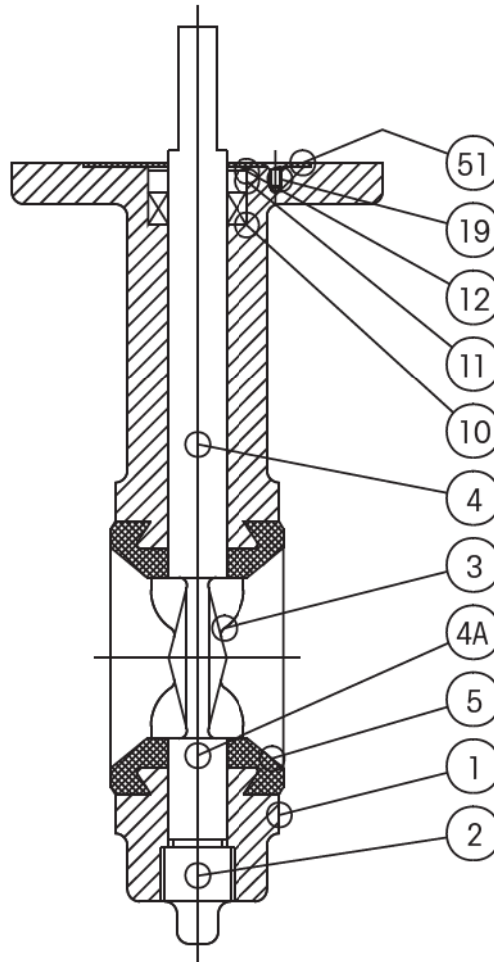

Pos.	Bezeichnung / Description		Material / Material	
1	Gehäuse	Body	Guß GGG-40	Cast iron GGG-40
2	Verschluss	Plug	Stahl vernickelt	Steel nickel-plated
3	Scheibe	Disc	• Edelstahl 1.4408	• Stainless steel 1.4408
4	Obere Spindel	Upper stem	• Edelstahl 1.4016	• Stainless steel 1.4016
4a	Untere Spindel	Lower stem	• Edelstahl 1.4016	• Stainless steel 1.4016
5	Manschette	Seat	• NBR • FKM • EPDM	• NBR • FKM • EPDM
10	Spindeldichtung	Stem seals	• FKM • EPDM	• FKM • EPDM
11	Buchse	Bush	POM	POM
12	Scheibe	Ring	Federstahl	steel for spring
19	Schraube	Screw	Stahl vernickelt	Steel nickel-plated
51	Scheibe	Washer	Stahl vernickelt	Steel nickel-plated

Abmessungen / Dimension

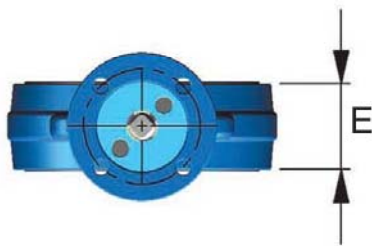
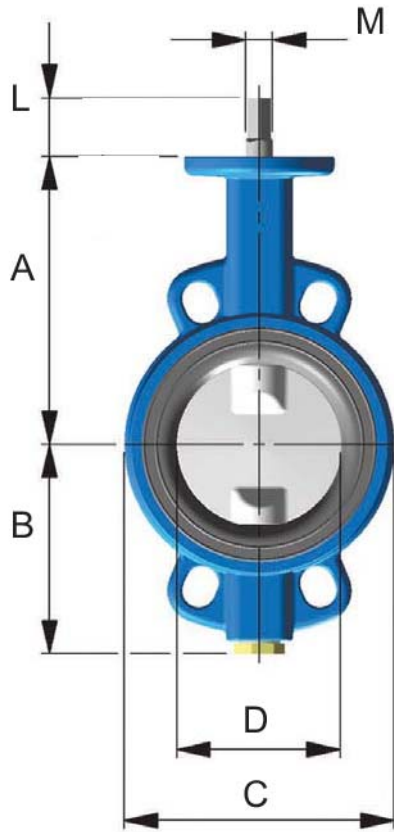

LUG- Type / LUG type

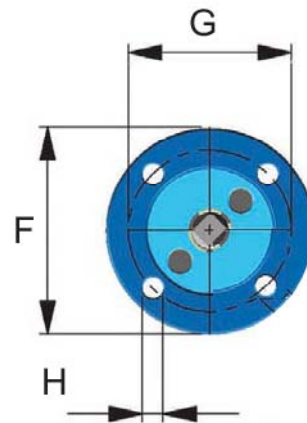
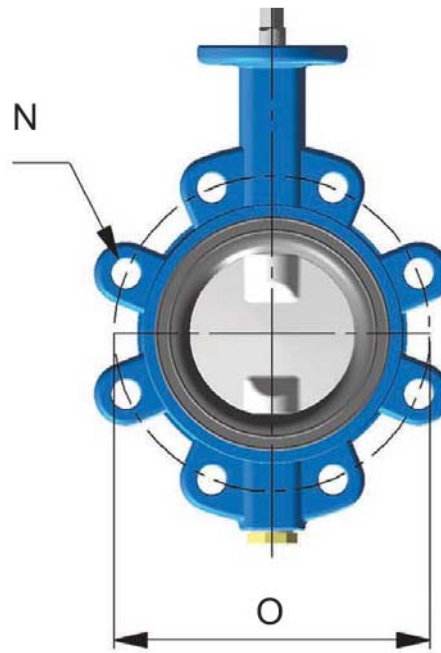

DN	D	C	B	A	L	M	E	F	G	n x ØH	PN 10		PN 16		kg
											n x N	O	n x N	O	
40	40	85	59	120	33	14	40	90	70	4 x 9	4 x M16	110	4 x M16	110	2,7
50	50	92	64	130	33	14	43	90	70	4 x 9	4 x M16	125	4 x M16	125	2,9
65	63	107	72	137	33	14	46	90	70	4 x 9	4 x M16	145	4 x M16	145	4,1
80	77	122	85	156	33	16	46	90	70	4 x 9	8 x M16	160	8 x M16	160	4,4
100	100	150	95	170	33	16	52	90	70	4 x 9	8 x M16	180	8 x M16	180	4,7
125	125	179	110	185	33	19	56	90	70	4 x 9	8 x M16	210	8 x M16	210	6,3
150	147	206	123	203	33	19	56	90	70	4 x 9	8 x M20	240	8 x M20	240	7,9
200	198	257	168	238	33	19	60	90	70	4 x 9	8 x M20	295	12 x M20	295	12,3
250	244	316	203	270	65	22	68	125	102	4 x 12	12 x M20	350	12 x M24	355	19,5
300	298	370	242	310	65	28	78	125	102	4 x 12	12 x M20	400	12 x M24	410	30,5
350	337	410	290	330	65	28	78	125	102	4 x 12	16 x M20	460	16 x M24	470	41,0
400	387	468	330	375	75	38	102	175	140	4 x 18	16 x M24	515	16 x M27	425	62,0
500	487	578	400	440	100	45	127	210	165	4 x 22	20 x M24	620	20 x M30	650	111,0
600	575	680	460	510	100	55	154	210	165	4 x 22	20 x M24	725	20 x M30	770	210,0

Losbrechdrehmoment [Nm] / Breakaway torques [Nm]

Das Losbrechdrehmoment kann in Abhängigkeit der Betriebsbedingungen, Medium und Dichtungswerkstoff variieren; es sollte daher ein Sicherheitsfaktor von 1,5 berücksichtigt werden.

The values of the breakaway torque may vary as a function of the seat material, temperature and type of medium, therefore it is necessary to consider a safety factor of 1,5.

	DN	40	50	65	80	100	125	150	200	250	300	350	400	500	600
PN - bar	0	11	14	18	27	40	59	88	157	248	343	485	662	1142	2385
	6	11	20	25	32	41	62	92	173	275	382	549	766	1327	2787
	10	12	23	27	33	54	71	106	186	321	576	680	882	1634	3250
	16	14	25	29	37	56	86	123	262	392	551	1528	2035	3070	5670

Kv-Wert [m³/h] / Kv-rate [m³/h]

in Abhängigkeit vom Öffnungswinkel / as a function of opening angle

	DN	40	50	65	80	100	125	150	200	250	300	350	400	500	600
Winkel / angle [°]	20	2,7	6,7	8,6	13	23	50	83	142	220	319	388	552	785	1078
	30	4,3	7,8	13	20	35	74	121	211	328	466	647	776	1375	1974
	40	9,5	16	23	34	61	129	211	354	560	819	1120	1483	2457	3448
	50	16	24	38	56	99	211	345	591	974	1353	1905	2405	3991	5250
	60	22	48	73	112	198	414	677	1099	1810	2629	3517	4310	7414	10776
	70	39	62	95	142	259	526	871	1478	2328	3405	4836	6336	9914	14224
	80	60	95	145	216	401	845	1392	2302	3664	5129	6964	9284	15121	20336
	90	69	116	181	267	466	948	1647	2746	4224	6336	9655	11121	19310	24397

$$C_v = 1,16 \cdot K_v$$