



Qualität von Anfang an.

## Technische Daten

### BAUFORM

1-teiliges Zentriergehäuse, mit auswechselbarer Manschette zum Einklemmen zwischen zwei Flansche nach EN 1092-1 Typ 11 Form B (PN10/PN16); andere auf Anfrage.

### BAULÄNGE

Nach EN 558-1 Reihe 20.

### BETÄTIGUNG

90°-Drehung des Handhebels, mit 10 Einrastmöglichkeiten und Stellungsanzeige.

### ANSCHLUß

Flansch DN 50 bis DN 300  
Größere Nennweiten auf Anfrage.

### BETRIEBSDRUCK

Artikel WA / WM\* (zwischen 2 Flanschen)  
DN 50 - DN 300: max. 16 bar  
DN 350 - größer: max. 10 bar  
FKM - Manschette: max. 6 bar

### Artikel WM\* (als Endklappe)

max. 10 bar  
FKM - Manschette: max. 6 bar

### MEDIUMTEMPERATUR

NBR: -10°C bis max. + 80°C  
EPDM: -20°C bis max. +120°C  
FKM: -10°C bis max. +180°C  
(p<sub>max.</sub> = 6 bar)  
andere auf Anfrage

### WERKSTOFFE

Gehäuse: GG-25  
GGG-40  
Edelstahl 1.4408  
Scheibe: GGG-40  
Edelstahl 1.4408  
Wellendichtung: NBR / POM  
Welle: Edelstahl 1.4401  
Manschette: EPDM  
NBR  
FKM  
Handhebel: Sphäroguß,  
lackiert

### ZUSATZAUSSTATTUNG

Pneumatischer oder elektrischer Schwenkantrieb, elektrische Stellungsanzeige, Handhebel stufenlos verstellbar.

Alle Angaben sind freibleibend und unverbindlich!

\*Flansche PN16 - DN65 werden in 4-Loch-Ausführung geliefert!

## Specification

### DESIGN

Body consists of 1 part, with exchangeable seat to be mounted between two flanges acc. to EN 1092-1 Typ 11 Form B (PN10/PN16); others on request.

### FACE TO FACE LENGTH

Acc. to EN 558-1 R20.

### OPERATION

Rotation of the handle through 90°, with 10 snap-in positions and optical position indicator.

### CONNECTION

Flange DN 50 up to DN 300  
Bigger sizes on request.

### PRESSURE RANGE

Type WA / WM\* (between 2 flanges)  
DN 50 - DN 300: max. 16 bar  
DN 350 - bigger: max. 10 bar  
FKM - seat: max. 6 bar

### Type WM\* (dead end service)

max. 10 bar  
FKM - seat: max. 6 bar

### TEMPERATURE RANGE

NBR: -10°C up to max. + 80°C  
EPDM: -20°C up to max. +120°C  
FKM: -10°C up to max. +180°C  
(p<sub>max.</sub> = 6 bar)  
others on request

### MATERIALS

Body: GG-25  
GGG-40  
Stainless steel 1.4408  
Disc: GGG-40  
Stainless steel 1.4408  
Stem seal: NBR / POM  
Shaft: Stainless steel 1.4401  
Seat: EPDM  
NBR  
FKM  
Handle: Spheroidal cast iron,  
varnished

### OPTIONS

Pneumatic or electric actuator, electric position indicator, handle lockable in all positions.

The above information is intended for guidance only and the company reserves the right to change any data herein without prior notice!

\*Flanges PN16 - DN65 will be delivered in 4-hole execution!

Artikel:  
**WA / WM**

Absperrklappe  
PN 10/16

GG-25  
GGG-40  
Edelstahl



Type:  
**WA / WM**

Butterfly valve  
PN 10/16

GG-25  
GGG-40  
Stainless steel

## Artikel- u. Bestellangaben: z.B. WA534010

= Absperrklappe, GG-25, Edelstahl 1.4408, EPDM, DN 100

1. + 2. Stelle Produkt	3. Stelle Gehäusewerkstoff	4. Stelle Scheibenwerkstoff	5. Stelle Manschettenwerkstoff	6. Stelle Zusatzausstattung	7. + 8. Stelle Anschlußgröße
<b>WA</b> = Absperrklappe <b>WM</b> = Absperrklappe, Anflanschgehäuse	<b>3</b> = Edelstahl 1.4408 (Art. WA + WM) <b>5</b> = GG-25 (Art. WA) GGG-40 (Art. WM + WA DN200+DN300)	<b>3</b> = Edelstahl 1.4408 <b>5</b> = GGG-40	<b>2</b> = NBR <b>3</b> = FKM ( $p_{max.} = 6 \text{ bar}$ ) <b>4</b> = EPDM	<b>0</b> = ohne	<b>07</b> = DN 50 <b>08</b> = DN 65 <b>09</b> = DN 80 <b>10</b> = DN 100 <b>11</b> = DN 125 <b>12</b> = DN 150 <b>13</b> = DN 200 <b>14</b> = DN 250 <b>15</b> = DN 300  Größere Nennweiten auf Anfrage.

## Ordering example: e.g. WA534010

= Butterfly valve, GG-25, Stainless steel 1.4408, EPDM, DN 100

1. + 2. Digit Product	3. Digit Body material	4. Digit Disc material	5. Digit Seat material	6. Digit Options	7. + 8. Digit Connection size
<b>WA</b> = Butterfly valve Wafer type <b>WM</b> = Butterfly valve LUG-type	<b>3</b> = Stainl. steel 1.4408 (Art. WA + WM) <b>5</b> = GG-25 (Art. WA) GGG-40 (Art. WM + WA DN200+DN300)	<b>3</b> = Stainless steel 1.4408 <b>5</b> = GGG-40	<b>2</b> = NBR <b>3</b> = FKM ( $p_{max.} = 6 \text{ bar}$ ) <b>4</b> = EPDM	<b>0</b> = no options	<b>07</b> = DN 50 <b>08</b> = DN 65 <b>09</b> = DN 80 <b>10</b> = DN 100 <b>11</b> = DN 125 <b>12</b> = DN 150 <b>13</b> = DN 200 <b>14</b> = DN 250 <b>15</b> = DN 300  Bigger sizes on request

## EU-Herstellererklärung / EU-Declaration by the manufacturer

im Sinne der EU-Maschinenrichtlinie 98/37/EG (former 89/392/EWG, Anhang II B)  
Hiermit erklären wir, dass die Absperrklappen unter Anwendung nachfolgender harmonisierter  
Normen entwickelt und konstruiert wurden:

EN ISO 12100: 2004	Sicherheit von Maschinen
EN 983: 1996	Fluidtechnische Anlagen - Pneumatik
EN 60204-1: 1992	Elektrische Ausrüstung von Maschinen

**Hinweis**  
Die Absperrklappen sind zum Einbau in eine Maschine bestimmt. Deren Inbetriebnahme  
ist solange untersagt, bis festgestellt wurde, dass die Gesamtmaschine der EU-Richtlinie  
entspricht.

as defined by Machinery Directive 98/37/EC (former 89/392/EWG, Annex II B),  
we herewith declare that the butterfly valves have been developed and designed by applying  
the following harmonised standards:

EN ISO 12100: 2004	Safety of machinery
EN 983: 1996	Safety requirements for fluid power systems and components - Pneumatics
EN 60204-1: 1992	Electrical equipment of machinery

**Advice**  
These butterfly valves are intended to be incorporated into machinery compounds. Putting into  
operation of the machinery is not allowed until such time as the entire machinery is proving to  
comply completely with the EU Directive.

## Aufbau / Construction

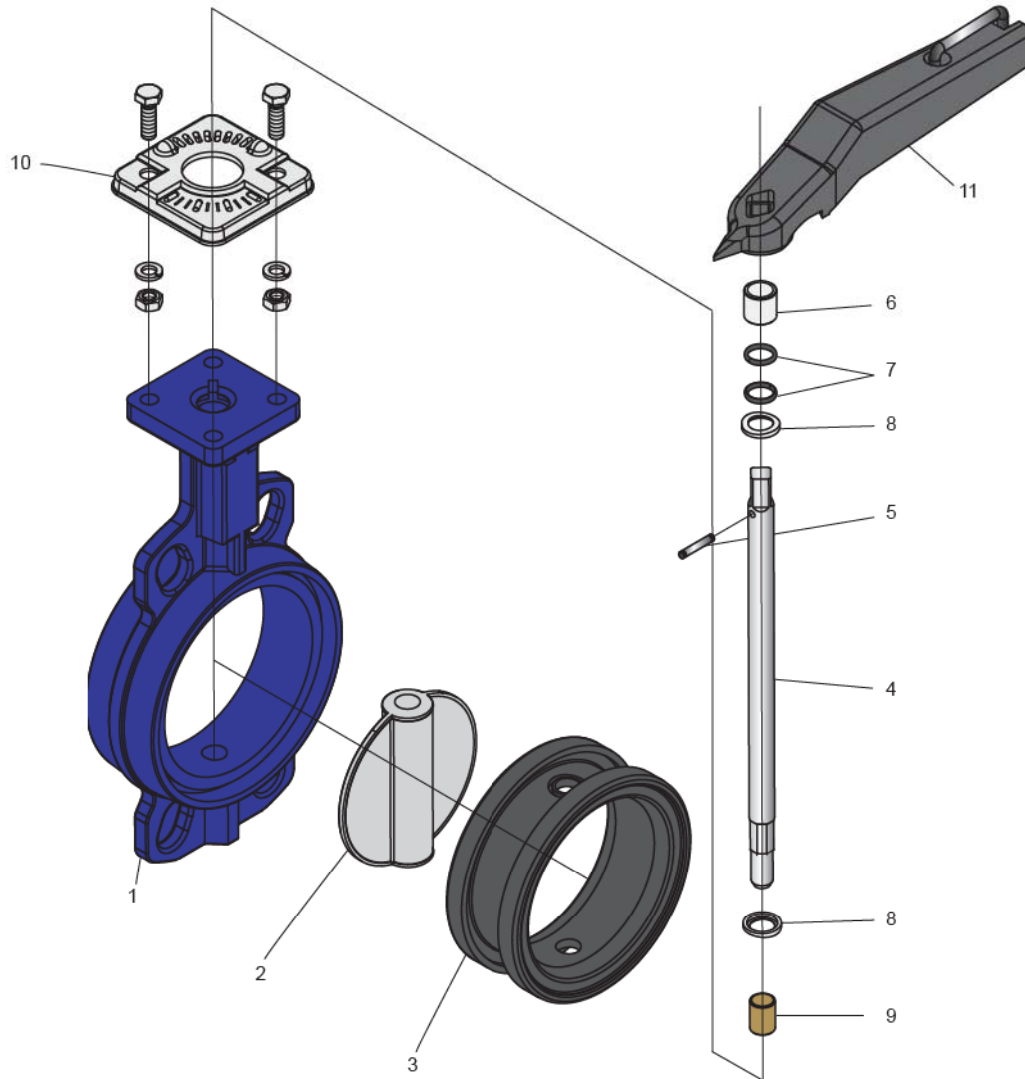

Pos.	Bezeichnung	/ Description	Material	/ Material
1	Gehäuse	Body	GG-25 (Art. WA)	GG-25 (Art. WA)
			GGG-40 (Art. WM + WA DN200 + DN300)	GGG-40 (Art. WM + WA DN200 + DN300)
			Edelstahl 1.4408 (Art. WA + WM)	stainless steel CF8M (Art. WA + WM)
2	Scheibe	Disc	GGG-40	GGG-40
			Edelstahl 1.4408	stainless steel CF8M
3	Sitz	Seat	NBR	NBR
			EPDM	EPDM
			FKM	FKM
4	Spindel	Stem	Edelstahl	stainless steel
5	Stift	Pin	Edelstahl	stainless steel
6	Buchse	Bush	POM	POM
7	O- Ring	O- ring	NBR	NBR
8	Verstärkungsring	Back up ring	Kunststoff	plastic
9	Buchse	Bush	Rotguss	bronze
10	Rastscheibe	Snap- in- disc	Stahl	steel
11	Handhebel	Handle	Guss	cast iron

Abmessungen Art. WA  
Dimensions Art. WA

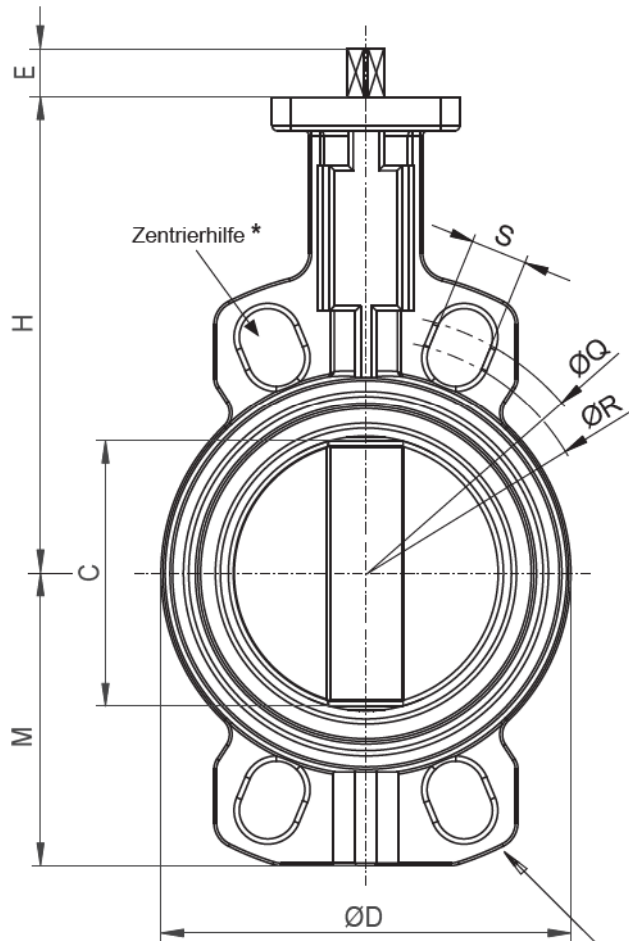

ab DN100 \*

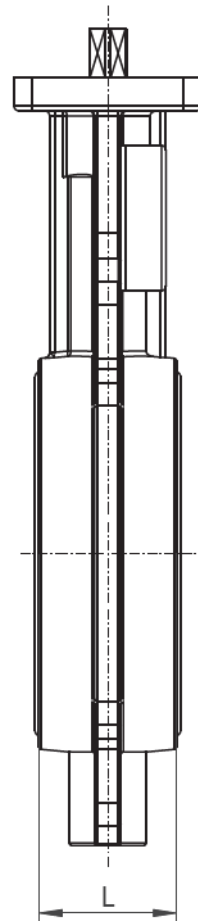

\* DN40 - DN65

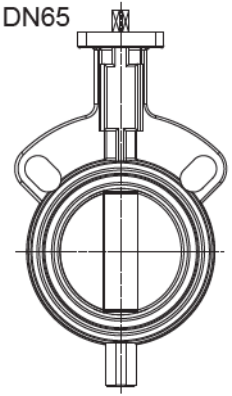

\* DN80

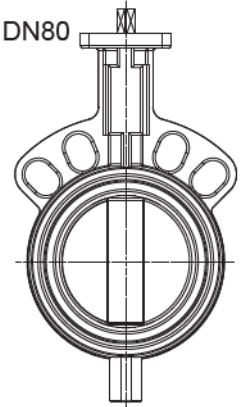

\* DN200 - DN300

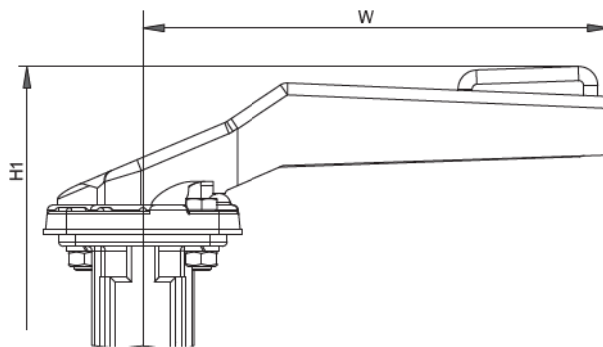
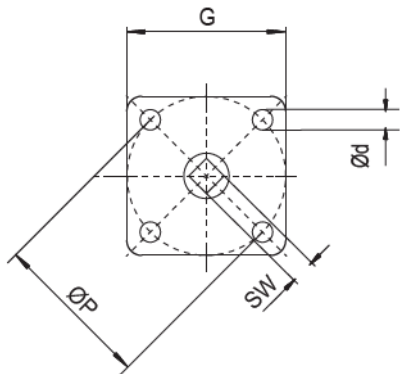
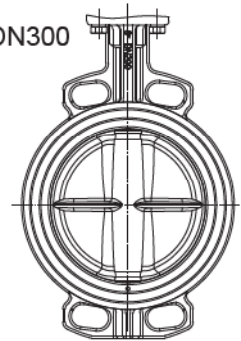

DN	C	L	H	M	H1	E	ØD	□G	ØP	ØQ	ØR	S	Ød	SW	W	kg*
50	50	43	143	65	204	19	96	70	F07	124	114	23	10	11	200	3,0
65	65	46	155	71	216	19	110	70	F07	127	145	23	10	11	200	3,8
80	80	46	162	77	223	19	124	70	F07	159	150	23	10	11	200	4,0
100	91	52	181	107	242	19	148	70	F07	190,6	175	23	10	11	200	5,2
125	115	56	197	122	258	19	180	70	F07	216	210	27	10	14	250	7,3
150	140	56	210	140	271	19	208	70	F07	242	235	24	10	14	250	8,2
200	186	60	240	165	308	24	259	100	F10	298,5	290	27	12	17	355	13,5
250	239	68	286	201	354	24	320	100	F10	362	350	27	12	19	355	21,2
300	288	78	309	234	377	24	370	100	F10	431,8	400	29	12	22	355	32,5

**Abmessungen Art. WM**  
**Dimensions Art. WM**

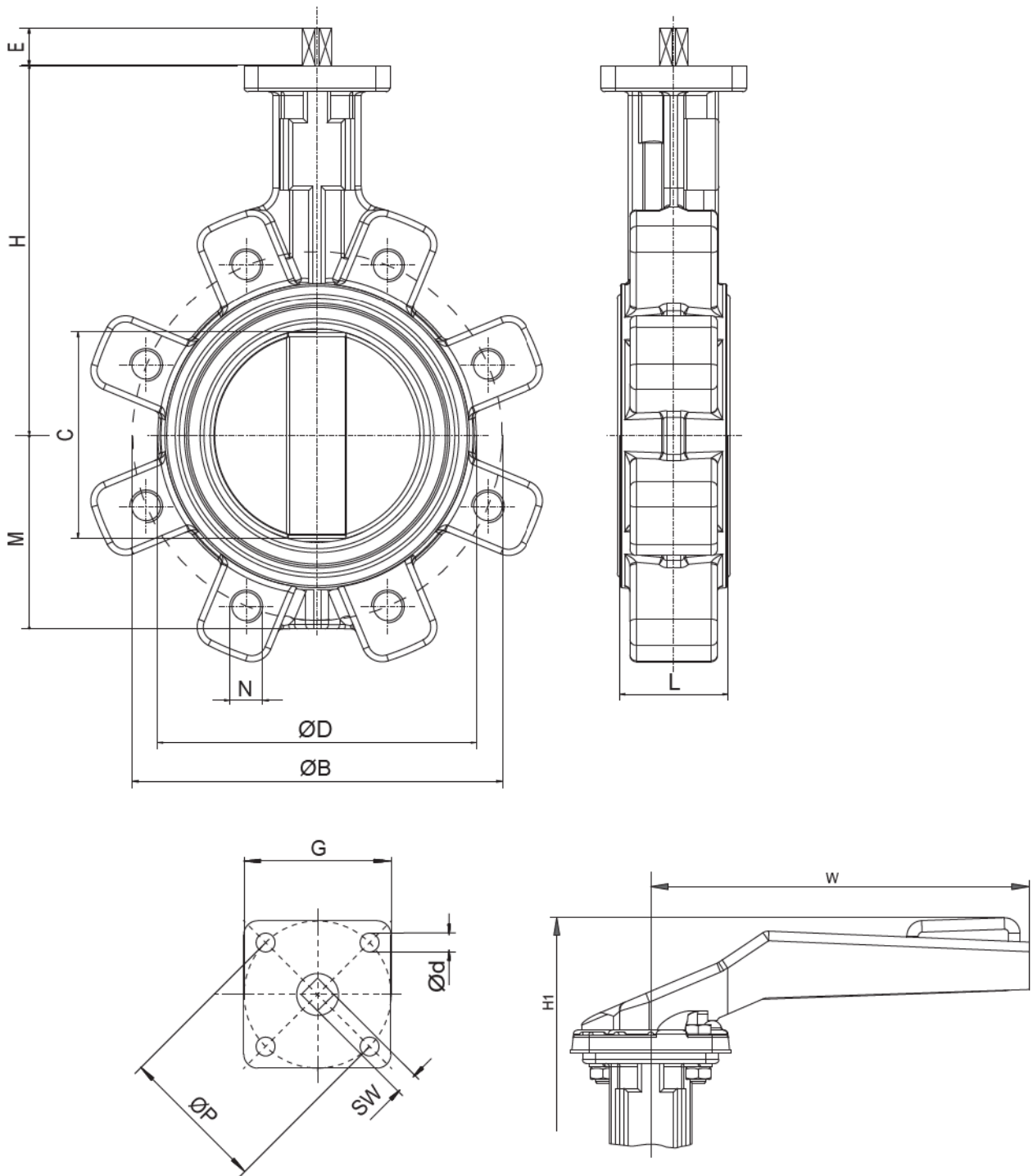

DN	C	L	H	M	H1	E	□G	ØP	Ød	ØD	SW	PN 16			kg	
												N	n	ØB		
50	57	43	143	65	204	19	70	F07	10	96	11	M16	4	125	200	3,4
65*	70	46	155	71	216	19	70	F07	10	110	11	M16	4	145	200	4,0
80	82	46	162	77	223	19	70	F07	10	124	11	M16	8	160	200	4,5
100	102	52	181	89	242	19	70	F07	10	148	11	M16	8	180	200	7,6
125	126	56	197	112	258	19	70	F07	10	180	14	M16	8	210	250	9,5
150	148	56	210	123	271	19	70	F07	10	208	14	M20	8	240	250	10,4
200	193	60	240	150	308	24	100	F10	12	259	17	M20	12	295	355	17,5
250	244	68	286	179	354	24	100	F10	12	320	19	M24	12	355	355	26,5
300	294	78	309	216	377	24	100	F10	12	370	22	M24	12	410	355	43,5

\* Flansche PN16 - DN65 werden in 4-Loch-Ausführung geliefert!  
 Flanges PN16 - DN65 will be delivered in 4-hole execution!