



Qualität von Anfang an.

Technische Daten

BAUFORM

Flansch-Kugelhahn als 2-teilige Körperkonstruktion, voller Durchgang, Flanschplatte für Antrieb nach ISO 5211, TA-Luft Zulassung, Anti-Statik-Ausführung nach BS 51466 (ISO 7121).

Fire-safe nach BS 6755/T2 (ISO 10497).

Minimaler Hohlraum zwischen Gehäuse und Kugel. Entlastungsbohrung in der Kugel.

BETÄTIGUNG

90°-Drehung des Handhebels

(Um jeweils 180° gegen die Spindel versetzbar).

ANSCHLUSS

Flansch DN 15 - DN 50: PN40

Flansch DN 65 - DN 200: PN16

Flansche PN16 - DN65 werden in 4-Loch-Ausführung geliefert!

BAULÄNGE

EN 558 - Reihe 27

TEMPERATUR

-20°C bis max. +160°C

WERKSTOFFE

Gehäuse: Edelstahl 1.4408
Stahl GS-C25

Kugel: Edelstahl

Kugeldichtung: PTFE

Spindeldichtung: PTFE / Graphit

/ FKM

Handhebel: Edelstahl

Stahl

ZUSATZAUSSTATTUNG

Pneumatischer oder elektrischer

Schwenkantrieb, hohlraumarm,

Flanschbohrungen nach ANSI 150 Lbs.

Alle Angaben sind freibleibend und unverbindlich!

Specification

DESIGN

Flanged ball valve

2-piece designed, full bore, mounting pad for actuator according to ISO 5211, TA-Luft approval, Anti-static device acc. to BS 51466 (ISO 7121).

Fire-safe acc. to BS 6755/T2 (ISO10497).

Minimum cavity space between ball and body. Ball with relief hole to keep the cavities at the same pressure.

OPERATION

Rotation of the handle through 90°.

(Handle is reversible through 180°).

CONNECTION

Flange DN 15 - DN 50: PN40

Flange DN 65 - DN 200: PN16

Flanges PN16 - DN65 will be delivered in 4-hole execution!

FACE TO FACE DIMENSION

EN 558 - R 27

TEMPERATURE RANGE

-20°C up to +160°C

MATERIALS

Body: Stainless steel 1.4408

Carbon steel GS-C25

Ball: Stainless steel

Ball seal: PTFE

Spindle seal: PTFE / Graphite

/ FKM

Handle: Stainless steel

Carbon steel

OPTIONS

Pneumatic or electric actuator, electrical

position indicator, minimum cavity space,

Flange dimensions acc. to ANSI 150 Lbs.

The above information is intended for guidance only and the company reserves the right to change any data herein without prior notice!

Artikel:
VS

2-Wege - Kugelhahn
voller Durchgang
PN 40/16

Stahl
Edelstahl



Type:
VS

2-way - Ball valve
full bore
PN40/16

Carbon steel
Stainless steel



Artikel- u. Bestellangaben: z.B. **VS311007** =
2-Wege - Kugelhahn, Edelstahl, handbetätigt, DN 50

1. + 2. Stelle Produkt	3. + 4. Stelle Werkstoffe Gehäuse / Dichtung / Kugel	5. Stelle Betätigung	6. Stelle Optionen	7. + 8. Stelle Anschluß
VS = 2-Wege Kugelhahn, voller Durchgang	31 = Edelstahl / PTFE / Edelstahl 41 = Stahl / PTFE / Edelstahl	1 = Handhebel	0 = ohne	02 = DN 15 03 = DN 20 04 = DN 25 05 = DN 32 06 = DN 40 07 = DN 50 08 = DN 65 09 = DN 80 10 = DN 100 11 = DN 125 12 = DN 150 13 = DN 200

Ordering example: e.g. **VS311007** =
2-way Ball valve, Stainless steel, Handle, DN 50

1. + 2. Digit Product	3. + 4. Digit Materials Body / seals / ball	5. Digit Operation	6. Digit Options	7. + 8. Digit Connection
VS = 2-way Ball valve, full bore	31 = Stainless steel / PTFE / Stainless steel 41 = Carbon steel / PTFE / Stainless steel	1 = Handle	0 = ohne	02 = DN 15 03 = DN 20 04 = DN 25 05 = DN 32 06 = DN 40 07 = DN 50 08 = DN 65 09 = DN 80 10 = DN 100 11 = DN 125 12 = DN 150 13 = DN 200

**Stückliste (Stahl Ausführung) /
Parts list (Carbon steel version)**

Pos.	Bezeichnung	Description	Material	Material
1	Gehäuse	Body	Stahl GS-C25	Carbon steel GS-C25
2	Muffe	Cap	Stahl GS-C25	Carbon steel GS-C25
3	Kugel	Ball	Edelstahl 1.4301 (DN15 - DN40) Edelstahl 1.4308 (DN50 - DN200)	Satinless steel 1.4301 (DN15 - DN40) Stainless steel 1.4308 (DN50 - DN200)
4	Spindel	Stem	Edelstahl 1.4401	Stainless steel 1.4401
5	Schraube	Screw	Stahl	Carbon steel
6	Mutter	Nut	Stahl	Carbon steel
7	Tellerfeder	Spring washer	Edelstahl 1.4310	Stainless steel 1.4310
8	90° Stop	90° Stop	Stahl	Carbon steel
9	Vorspannring	Packing gland	Stahl	Carbon steel
10	Spindeldichtung	Stem seal	PTFE	PTFE
11	Handhebel	Handle	Stahl	Carbon steel
12	Spindeldichtung	Stem seal	Graphit	Graphite
13	O- Ring	O- ring	FKM	FKM
14	Spindeldichtung	Thrust washer	PTFE	PTFE
15	Gehäusedichtung	Body seal	Graphit	Graphite
16	Gehäusedichtung	Body seal	PTFE	PTFE
17	Kugeldichtung	Ball seal	PTFE	PTFE
18	Anti- Static- Ausführung	Anti-Static-device	Edelstahl 1.4401	Stainless steel 1.4401
19	Schraube	Screw	Stahl	Carbon steel

**Stückliste (Edelstahl Ausführung) /
Parts list (Stainless steel version)**

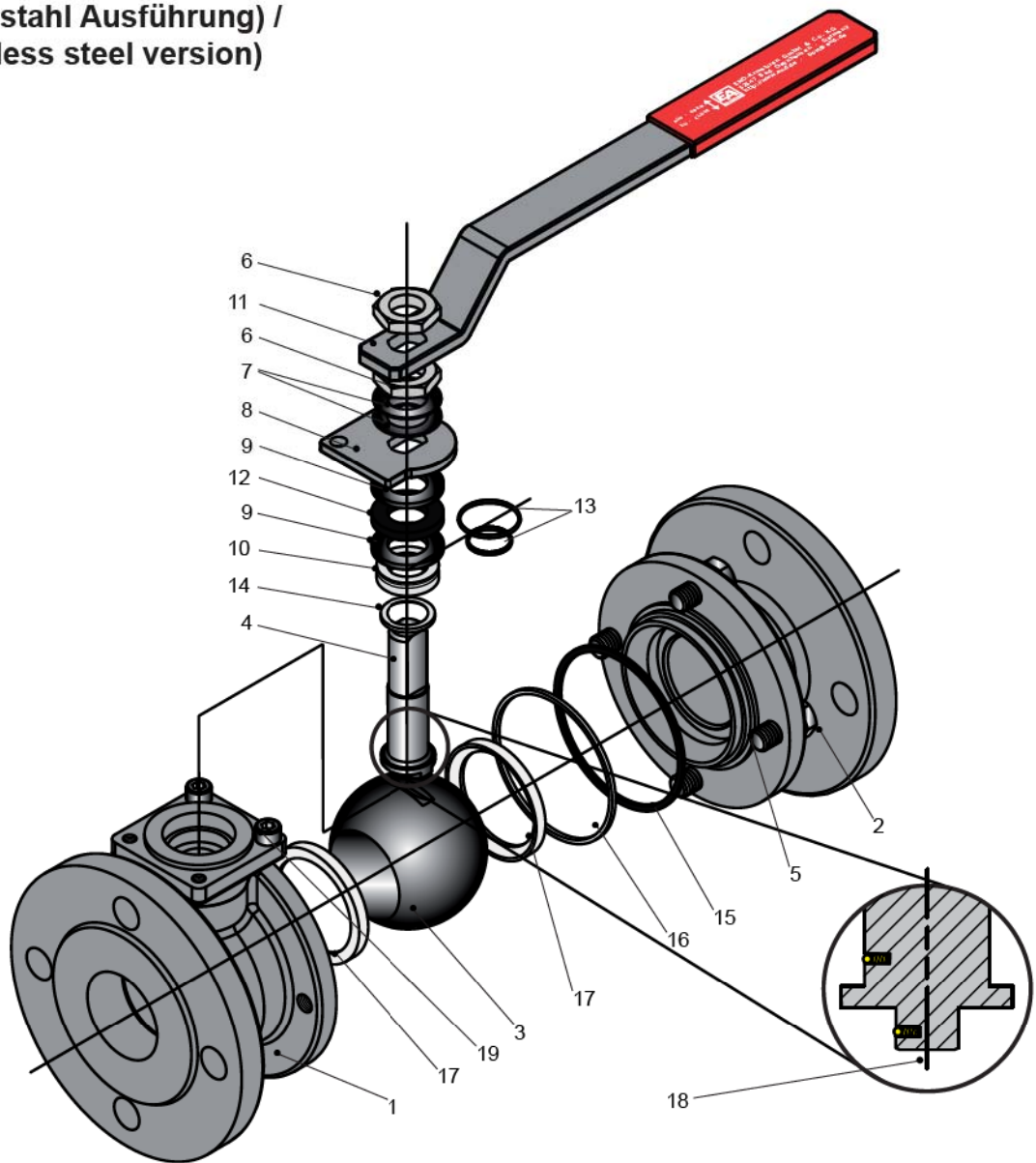

Pos.	Bezeichnung	Description	Material	Material
1	Gehäuse	Body	Edelstahl 1.4408	Stainless steel 1.4408
2	Muffe	Cap	Edelstahl 1.4408	Stainless steel 1.4408
3	Kugel	Ball	Edelstahl 1.4401 (DN15 - DN40) Edelstahl 1.4408 (DN50 - DN200)	Satinless steel 1.4401 (DN15 - DN40) Stainless steel 1.4408 (DN50 - DN200)
4	Spindel	Stem	Edelstahl 1.4401	Stainless steel 1.4401
5	Schraube	Screw	Edelstahl A2	Stainless Steel A2
6	Mutter	Nut	Edelstahl A2	Stainless steel A2
7	Tellerfeder	Spring washer	Edelstahl 1.4310	Stainless steel 1.4310
8	90° Stop	90° Stop	Edelstahl 1.4401	Stainless steel 1.4401
9	Vorspannring	Packing gland	Edelstahl 1.4401	Stainless steel 1.4401
10	Spindeldichtung	Stem seal	PTFE	PTFE
11	Handhebel	Handle	Edelstahl 1.4401	Stainless steel 1.4401
12	Spindeldichtung	Stem seal	Graphit	Graphite
13	O- Ring	O- ring	FKM	FKM
14	Spindeldichtung	Thrust washer	PTFE	PTFE
15	Gehäusedichtung	Body seal	Graphit	Graphite
16	Gehäusedichtung	Body seal	PTFE	PTFE
17	Kugeldichtung	Ball seal	PTFE	PTFE
18	Anti- Static- Ausführung	Anti-Static-device	Edelstahl 1.4401	Stainless steel 1.4401
19	Schraube	Screw	Edelstahl A2	Stainless steel A2

Abmessungen / Dimensions

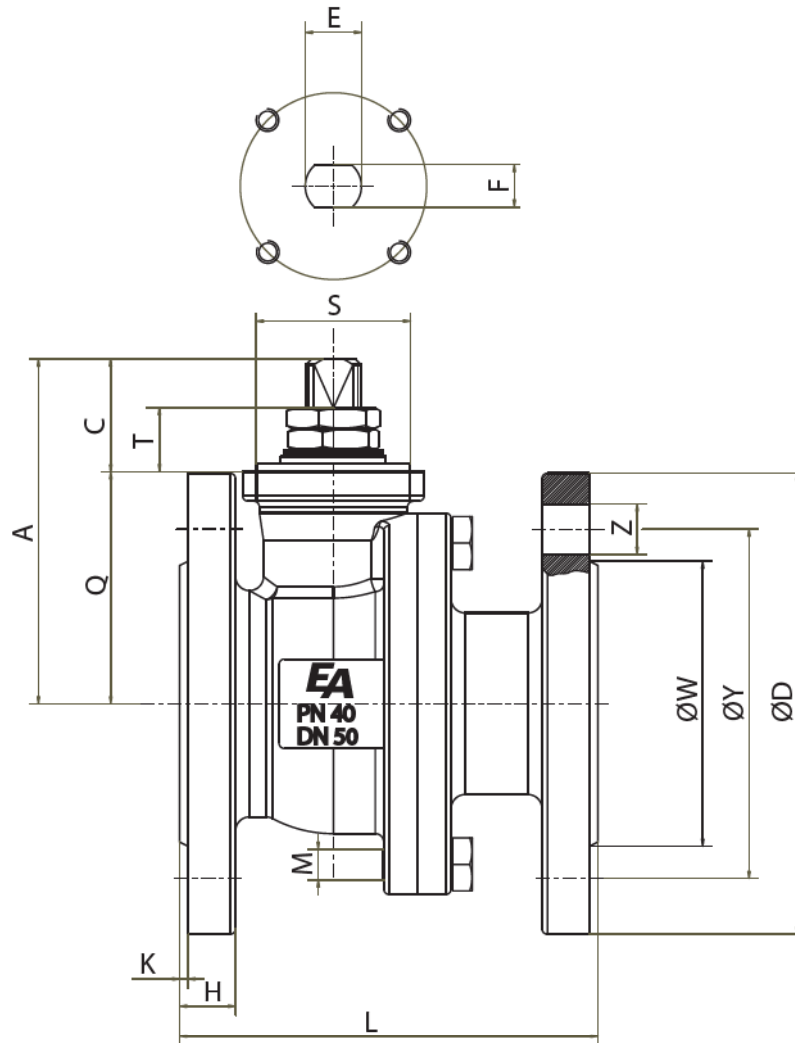

G	DN	ISO 5211	A	Q	C	E	F	S	T	M	ØD	ØY	Z	L	ØW	H	K	PN
½"	15	F04	51	32	18	M10	7	30	11	4xM10	95	65	4xØ14	115	45	16	2	40
¾"	20	F04	53	34	18	M10	7	30	11	4xM10	105	75	4xØ14	120	58	18	2	40
1"	25	F05	70	45	25	M12	8	35	14	4xM10	115	85	4xØ14	125	68	18	2	40
1¼"	32	F05	73	49	25	M12	8	35	14	4xM10	140	100	4xØ18	130	78	18	2	40
1½"	40	F05	107	76	31	M16	10	35	20	4xM12	150	110	4xØ18	140	88	18	3	40
2"	50	F07	122	83	38	M20	14	55	21	4xM12	165	125	4xØ18	150	102	20	3	40
2½"	65*	F07	133	93	39	M20	14	55	21	4xM16	185	145	4xØ18	170	122	18	3	16
3"	80	F10	15	108	43	M24	18	70	24	8xM12	200	160	8xØ18	180	138	20	3	16
4"	100	F10	165	122	43	M24	18	70	24	8xM12	220	180	8xØ18	190	158	20	3	16
5"	125	F 10	187	144	42,7	M24	18	70	23	8xM16	250	210	8xØ18	325	188	22	3	16
6"	150	F12	245	177	68	M42	30	85	40	8xM16	285	240	8xØ22	350	212	22	3	16
8"	200	F12	288	220	68	M42	30	85	40	8xM20	340	295	12xØ22	400	268	24	3	16

* Flansch PN16 DN65 werden in 4 Loch Ausführung geliefert!
Flanges PN16 - DN65 will be delivered in 4-hole execution!

EU-Herstellererklärung / EU-Declaration by the manufacturer

im Sinne der EU-Maschinenrichtlinie 98/37/EG (früher 89/392/EWG, Anhang II B)
Hiermit erklären wir, dass die Kugelhähne unter Anwendung nachfolgender harmonisierter Normen entwickelt und konstruiert wurden:

EN ISO 12100: 2004	Sicherheit von Maschinen
EN 983: 1996	Fluidtechnische Anlagen - Pneumatik
EN 60204-1: 1992	Elektrische Ausrüstung von Maschinen

as defined by Machinery Directive 98/37/EC (former 89/392/EWG, Annex II B),
we herewith declare that the ball valves have been developed and designed by applying the following harmonised standards:

EN ISO 12100: 2004	Safety of machinery
EN 983: 1996	Safety requirements for fluid power systems and components - Pneumatics
EN 60204-1: 1992	Electrical equipment of machinery

Hinweis
Die Kugelhähne sind zum Einbau in eine Maschine bestimmt. Deren Inbetriebnahme ist solange untersagt, bis festgestellt wurde, dass die Gesamtmaschine der EU-Richtlinie entspricht.

Advice
These ball valves are intended to be incorporated into machinery compounds. Putting into operation of the machinery is not allowed until such time as the entire machinery is proving to comply completely with the EU Directive.