



Qualität von Anfang an.

Technische Daten

BAUFORM

2- teilige Körperkonstruktion (verschraubt)

ANSCHLUSS

Innengewinde: 1/4" - 2", (DIN 2999);

EINBAULAGE

Beliebig, Durchflußrichtung beachten.

MEDIUMDRUCK

max. 40 bar

ÖFFNUNGSDRUCK

Siehe Tabelle Seite 3

TEMPERATUR

PTFE: -30°C bis max. +140°C

(bei Temperaturen über 50°C:

Druck- Temperatur- Diagramm beachten)

WERKSTOFFE

Gehäuse: Edelstahl 1.4408
Deckel: Edelstahl 1.4408
metallische Innenteile: Edelstahl 1.4404
Feder: Edelstahl 1.4310
Dichtung: PTFE

Alle Angaben sind freibleibend und unverbindlich!

Specification

DESIGN

Body consists of two screwed parts

CONNECTION

Female thread: 1/4" - 2", (DIN 2999);

MOUNTING POSITION

As desired, please refer to flow direction.

PRESSURE RANGE

max. 40 bar

ACTION PRESSURE

refer to table page 3

TEMPERATURE RANGE

PTFE: -30°C up to max. +140°C

(for temperatures exceeding 50°C please refer

to the Pressure- Temperature- Diagram)

MATERIAL

Body: Stainless steel 1.4408
Cover: Stainless steel 1.4408
metallic inner parts: Stainless steel 1.4404
Spring: Stainless steel 1.4310
Seal: PTFE

The above information is intended for guidance only and the company reserves the right to change any data herein without prior notice!

Artikel:

VB

Rückschlagventil

PN 40

Edelstahl



Type:

VB

Non-return valve

PN 40

Stainless steel



Artikel- u. Bestellangaben: z.B. VB310025

= Rückschlagventil, Edelstahl / PTFE, 1"

1.+ 2. Stelle Produkt	3.+ 4. Stelle Werkstoffe Gehäuse / Dichtung	5. Stelle Betätigung	6. Stelle Optionen	7. - 10. Stelle Anschlußgröße
VB= Rückschlagventil	31 = Edelstahl / PTFE	0 = ohne	0 = ohne	Gewinde 23 = G 1/2 24 = G 3/4 25 = G 1 26 = G 1 1/4 27 = G 1 1/2 28 = G 2 29 = G 2 1/2 30 = G 3

Ordering example: e.G. VB310025

= Non-return valve, stainless steel / PTFE, 1"

1.+ 2. Digit Product	3.+ 4. Digit Material Body / Sealing	5. Digit Operation	6. Digit Options	7. - 10. Digit Connecting size
VB= Non-return valve	31 = Stainless steel / PTFE	0 = without	0 = no options	threaded connection 23 = G 1/2 24 = G 3/4 25 = G 1 26 = G 1 1/4 27 = G 1 1/2 28 = G 2 29 = G 2 1/2 30 = G 3

Aufbau / Construction :

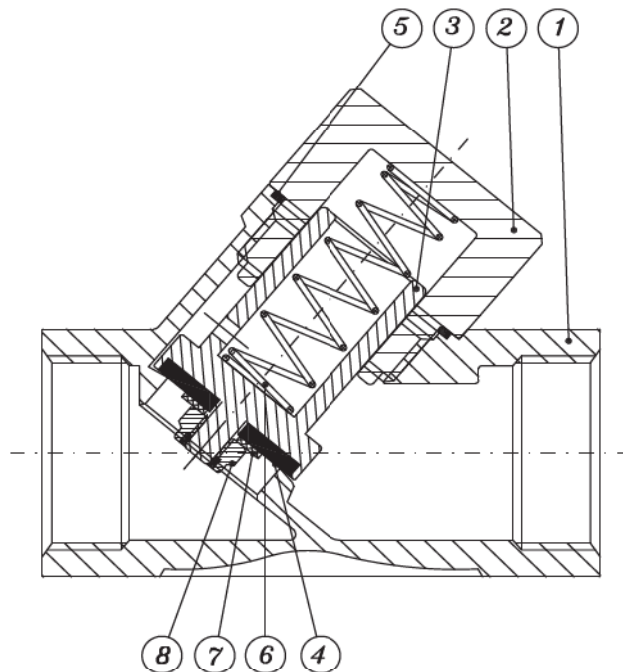

Pos.	Bezeichnung	Description	Material	Material
1	Gehäuse	Body	Edelstahl 1.4408	Stainless steel 1.4408
2	Deckel	Cap	Edelstahl 1.4408	Stainless steel 1.4408
3	Sitz	Discs	Edelstahl 1.4404	Stainless steel 1.4404
4	Sitzdichtung	Seat	PTFE	PTFE
5	Gehäusedichtung	Joint gasket	PTFE	PTFE
6	Feder	Spring	Edelstahl 1.4310	Stainless steel 1.4310
7	Mutter (selbstsichernd)	Nut	Edelstahl	Stainless steel
8	Scheibe	Washer	Edelstahl 1.4301	Stainless steel 1.4301

Abmessungen / dimensions :

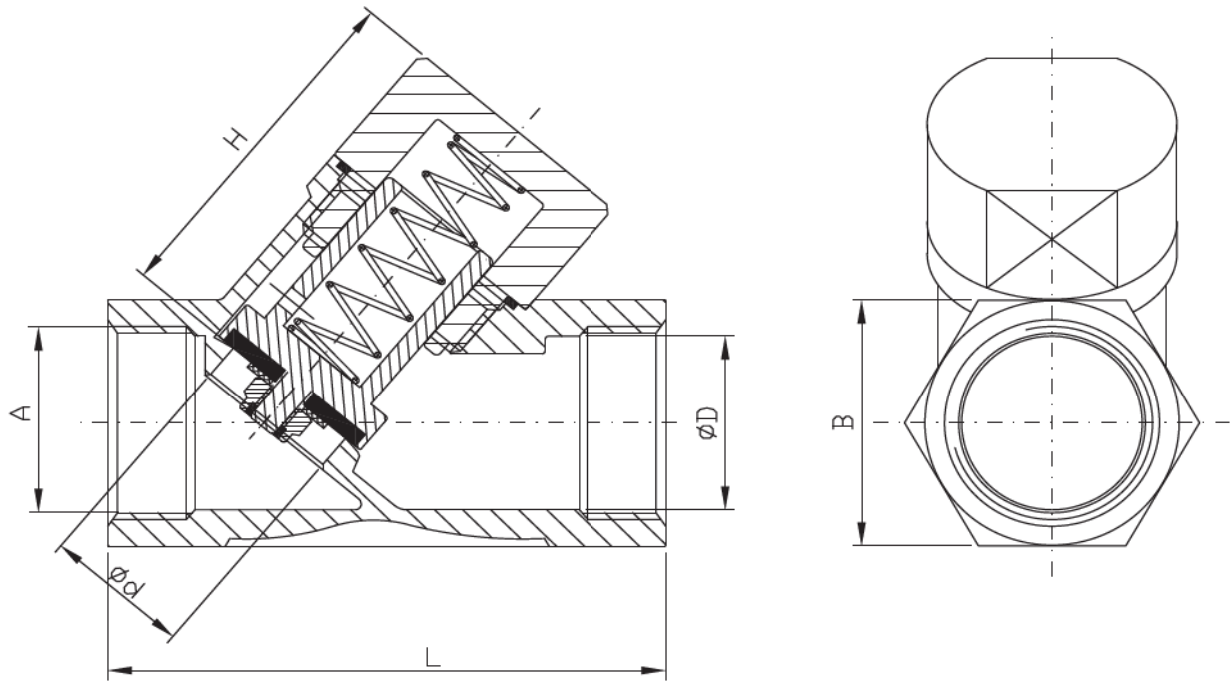

A	ØD	B	ød	H	L	p [bar]*
¼"	11,7	27	11,6	34,4	66	0,25
⅜"	14,0	27	12,5	34,4	66	0,25
½"	17,0	27	12,5	34,4	66	0,25
¾"	23,0	32	18,0	44,6	76	0,25
1"	29,0	41	23,5	56,9	90	0,25
1¼"	38,0	50	31,4	64,2	110	0,30
1½"	44,0	55,5	35,7	76,0	121	0,40
2"	56,0	70	45,5	87,0	152	0,40

*) : Öffnungsdruck / opening pressure

Druck- Temperatur- Diagramm / Pressure- Temperature- Diagram :

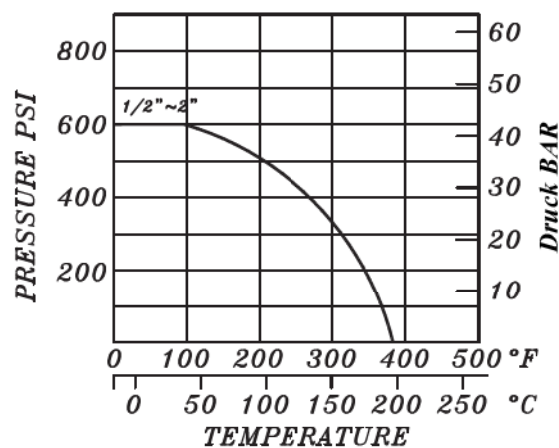

Hinweis

Bei den in dieser Dokumentation beschriebenen Produkten, in der von uns gelieferten Form, handelt es sich weder um Maschinen gemäß Artikel 2 Absatz a noch um unvollständige Maschinen gemäß Artikel 2 Absatz g im Sinne der Richtlinie 2006/42/EG über Maschinen.

Advice

The products described in this documentation in the conditions of our delivery are no machinery according to annex 2 paragraph a respectively no partly completed machinery according to annex 2 paragraph g of the directive 2006/42/EC on machinery.